

Cisco - EMC Transformational Data Center Architecture

Atmos operates as a single entity that distributes content in an Active/Active paradigm using Cisco Nexus 7000, Cisco Nexus 5000, or Cisco Nexus 3000 platforms.

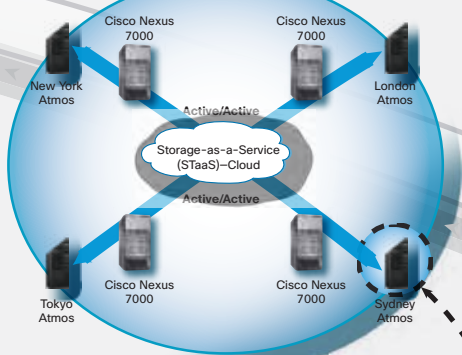

Cloud STaaS

Storage-as-a Service (STaaS), allows enterprises and service providers to meter capacity, bandwidth, and usage across multiple tenants. This helps enable users to self-manage and access storage.

The **Atmos** cloud storage platform enables enterprises and service providers to store, manage, and protect globally distributed, unstructured content at scale. **EMC Atmos** is the essential building block to implementing a private, public, or hybrid cloud storage environment.

Single system: Efficiently store, manage, and aggregate distributed big data across locations, using a common view and centralized management.

Seamless scalability: Add capacity, applications, locations, or tenants to your cloud with no need to develop or reconfigure. This reduces administration time and ensures availability.

Value-based automation: EMC Atmos uses customizable metadata to apply policies that automate data placement and lifecycle, protection methods, and efficiency, requiring minimal ongoing review, it enables you to manage big data, at scale.

Easy storage access: Flexible, instant access across networks and platforms for traditional applications, web applications, Windows, Linux, and mobile devices.

Disaster Avoidance

Disaster Avoidance is the ability to proactively and transparently move workloads for planned events or to avoid potential disasters.

Distributed: EMC VPLEX AccessAnywhere technology removes the boundaries between data centers, by making application data simultaneously available from two locations.

Dynamic: Administrators can non-disruptively move virtualized workloads from data centers in the path of a disaster (for example, a hurricane, flood, or fire), and then transparently transfer point-in-time copies when conditions are safe.

Smart Maintenance: Activities that traditionally require coordinated maintenance windows can now be performed with no downtime. EMC VPLEX and Cisco Overlay Transport Virtualization (OTV) not only make this possible, they make it simple.

Remote Replication: Ensure your mission-critical data has been captured down to the last transaction, by adding a second storage array at your remote site and installing the EMC Symmetrix Remote Data Facility (SRDF) family or MirrorView remote-replication software. Amp up the performance event even more by using the Connectrix MDS SAN Extension and the I/O Accelerator (IOA).

With these EMC and Cisco products you can help ensure that all your mission-critical information-down to the last transaction-has been captured. Your data center can be up and running in hours, not days.

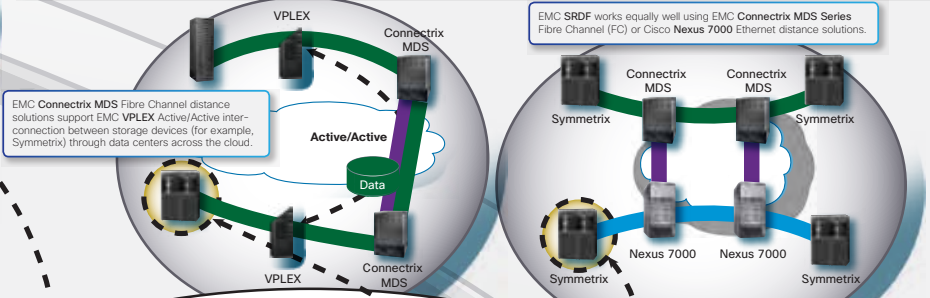

The **Atmos** cloud storage platform enables enterprises and service providers to store, manage, and protect globally distributed, unstructured content at scale. **EMC Atmos** is the essential building block to implementing a private, public, or hybrid cloud storage environment.

Single system: Efficiently store, manage, and aggregate distributed big data across locations, using a common view and centralized management.

Seamless scalability: Add capacity, applications, locations, or tenants to your cloud with no need to develop or reconfigure. This reduces administration time and ensures availability.

Value-based automation: EMC Atmos uses customizable metadata to apply policies that automate data placement and lifecycle, protection methods, and efficiency, requiring minimal ongoing review, it enables you to manage big data, at scale.

Easy storage access: Flexible, instant access across networks and platforms for traditional applications, web applications, Windows, Linux, and mobile devices.

World-Class Services

EMC Global Services and Cisco partner with you to assess, plan, design, and implement your future vision, whether for a pilot, greenfield, or enterprise-wide refresh. And with a complete lifecycle of advanced services, spanning both FCoE to traditional FC environments, we can help you evolve your vision, over time.

Hyper-Agility

Hyper-agility is the ability to modify and reconfigure data centers as needed, reducing application development times to near zero.

Flexibility in evolving the data center: A true converged network provides the ability to drastically reduce inefficient bandwidth. A converged networking environment provides a single, ubiquitous environment in which any storage can be run, including iSCSI, Network File System (NFS), Common Internet File System (CIFS), FC, and Fibre Channel over Ethernet (FCoE). Instead of creating protocol silos within the network, capacity planning can be based on aggregate needs over time, and allocation can be made on an as-needed basis with a simple, non-disruptive configuration change.

EMC Connectrix MDS Series and Cisco Nexus provide flexible solutions that meet your changing business requirements.

Simplicity across data centers: Cisco OTV significantly simplifies extending Layer 2 applications across distributed data centers. You can now deploy Data Center Interconnect (DCI) between sites without changing or reconfiguring your existing network design. With OTV, you can deploy virtual computing resources and clusters across geographically distributed data centers, delivering transparent workload mobility, business resiliency, and superior computing resource efficiencies.

The **VNX** modular architecture delivers optimum flexibility and performance without compromise. Storage processor modules manage the storage pool and provide SAN block-level access (iSCSI, FCoE), X-blades add scale-out shared network file support (CIFS, NFS with Parallel NFS [pNFS], or Multi-Path File System) and can be added independently without affecting the overall system or requiring planned downtime. In addition, **VNX** transparently supports Atmos for cloud connectivity and object protocols (REST or SOAP).

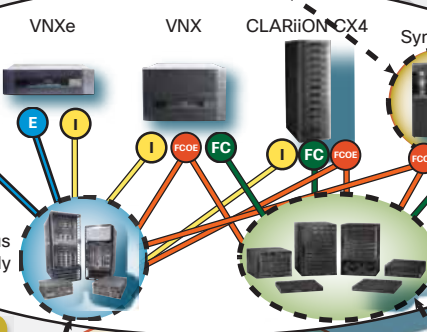

Cisco and EMC's broad range of storage portfolio solutions provides the most connectivity options between Symmetrix, VNX, Atmos, and CLARiiON; and connectivity to Cisco Nexus 7000, Nexus 5000, Nexus 3000, and EMC Connectrix MDS platforms.

Cisco's Nexus 7000, Nexus 5000, and Nexus 2000 provide the most flexibility and agility for multiprotocol converged networks, especially when combined with EMC's broad storage portfolio: Symmetrix, Atmos, VNX, and CLARiiON.

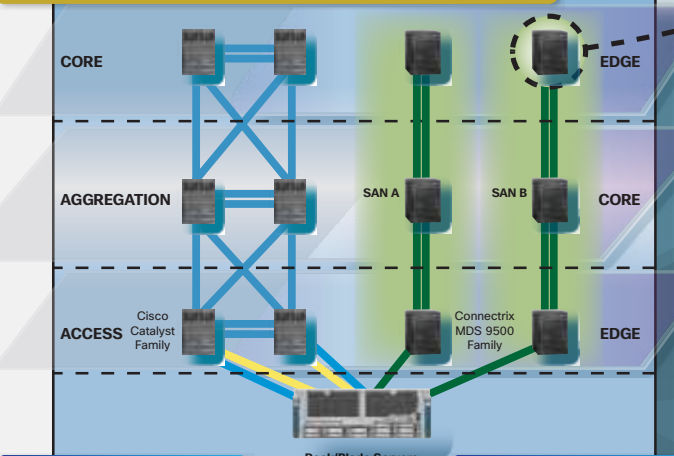
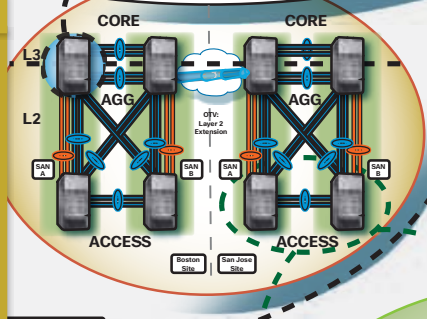
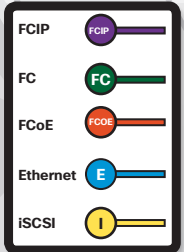

The Cisco Catalyst family of switches include the flagship, highly available Cisco Catalyst 6500, Cisco Catalyst 4500E, and stackable, fixed-configuration Cisco Catalyst 3750-X Series Switches for any type and size of LAN networking needs.

The EMC Connectrix MDS family of switches covers both fixed-port and highly-available models, such as the MDS 9506, MDS 9509, and MDS 9513 Multilayer Directors, as well as the MDS 9222I Multiservice Modular Switch that can implement intelligent fabric services and long-distance storage connectivity solutions.

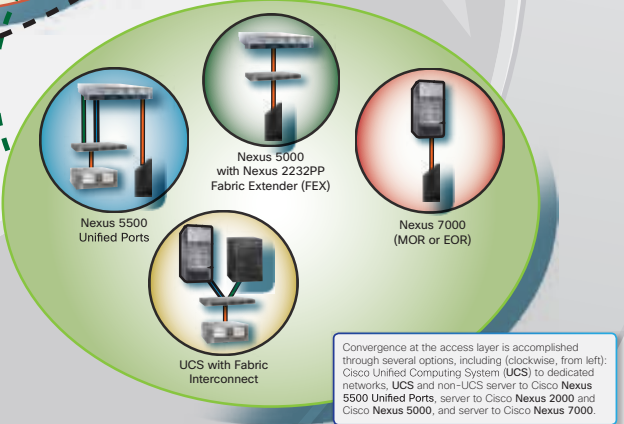

Convergence at the access layer is accomplished through several options, including (clockwise, from left): Cisco Unified Computing System (UCS) to dedicated networks; UCS and non-UCS server to Cisco Nexus 5500 Unified Ports; server to Cisco Nexus 2000 and Cisco Nexus 5000, and server to Cisco Nexus 7000.

Virtualization

Virtualization is the ability of a single physical platform to act like multiple platforms, an essential catalyst for cloud computing. This includes servers, networks, and federated storage.

Servers: Cisco and EMC offer simpler, highly secure, and scalable desktop and server virtualization solutions supported by Cisco Validated Designs (VDS) and EMC's Proven Solutions. These solutions support virtualized mission-critical applications, including Oracle and RISC-migration, Business Intelligence/Data Warehousing, Microsoft, and SAP. The VMPath feature in Cisco Data Center Network Manager supports path visualization and troubleshooting from the virtual machine (VM) all the way to the storage port. In turn, this empowers next-generation virtual workspaces with Cisco Virtualization Experience Infrastructure (VXI).

Networks: EMC Connectrix MDS and Cisco Nexus solutions for the converged infrastructure deliver flexible, standards-based storage network architecture with simpler, more cost-effective ways to use available bandwidth. Cisco Nexus 7000, Cisco Nexus 5000, and Cisco Nexus 2000 Series Switches provide a comprehensive toolbox to handle capacity, manage data traffic flow, and help ensure network security.

Whether separate or converged, SAN and LAN physical network resources can be virtualized, providing work load and administrative isolation as required in a shared physical network infrastructure.

By sharing network resources and using less physical hardware, IT can improve efficiency and reduce network administration costs. In addition to native Fibre Channel, EMC and Cisco converged network architecture support a range of protocols, including FCoE, iSCSI, and NAS, optimizing customer choice and flexibility.

Federated storage: This collection of autonomous storage resources, governed by a common management system, provides rules about how data is stored, managed, and migrated throughout the storage network. It includes disk capacity managed by controllers or appliances controlling multiple arrays. EMC's VMAX, VNX, VPLEX, and Atmos solutions exploit such architectures in block, file, and object environments.

Traditional Architectures

Traditional Data Center networks consist of separate Ethernet LANs and FC SANs. In order to satisfy continuously-evolving application requirements (for example, server virtualization), these isolated networks have continuously evolved over the past two decades. The result has been two independent, robust networks, each using a unique set of topologies, protocols, and best practices, with each being administered by a different group of IT professionals.

Maximum isolation: By restricting each type of traffic to its own physical network, each set of protocols can continue to be managed independently by a completely different group of people. This minimizes the impact that each team will have on the other during service activities (planned and unplanned).

Maximum flexibility: Since each protocol uses a different set of physical links, each protocol can continue to use a unique set of best practices and management tools without regard for the requirements of the other protocols in use.

Unprecedented investment protection: A traditional architecture allows for maximum isolation between networks and provides for maximum flexibility. EMC Connectrix MDS-Series offers customers unparalleled investment protection across a comprehensive selection of networked storage connectivity products. Connectrix MDS-Series integrates high-speed FC connectivity (2 to 8GB per second), highly resilient switching technology, and options for intelligent IP storage networking. Combine that with Cisco and EMC's industry-leading planning, design, and implementation services and you have everything you need to upgrade your FC infrastructure in one complete package.

